







- Relays of general application
- For plug-in sockets, 35 mm rail mount acc. to PN-EN 60715 or on panel mounting
- For PCB and for soldering connections
- AC and DC coils
- Recognitions, certifications, directives: RoHS,     

### Contact data

Number and type of contacts		2 C/O
Contact material		<b>AgNi</b> , AgNi/Au 0,2 μm, AgSnO <sub>2</sub>
Rated / max. switching voltage	AC	250 V / 250 V
Min. switching voltage		5 V AgNi, 5 V AgNi/Au 0,2 μm, 10 V AgSnO <sub>2</sub>
Rated load	AC1	5 A / 250 V AC
	DC1	5 A / 24 V DC
Min. switching current		5 mA AgNi, 5 mA AgNi/Au 0,2 μm, 10 mA AgSnO <sub>2</sub>
Rated current		5 A
Max. breaking capacity	AC1	1 250 VA
Min. breaking capacity		0,3 W AgNi, 0,3 W AgNi/Au 0,2 μm, 1 W AgSnO <sub>2</sub>
Contact resistance		≤ 100 mΩ
Max. operating frequency		
• at rated load	AC1	1 200 cycles/hour
• no load		36 000 cycles/hour

### Coil data

Rated voltage	50/60 Hz AC	6...240 V
	DC	6...110 V
Must release voltage		≥ 0,05 U <sub>n</sub>
Operating range of supply voltage		see Tables 1, 2
Rated power consumption	AC	1,2 VA
	DC	0,9 W

### Insulation according to PN-EN 60664-1

Insulation rated voltage		250 V AC
Rated surge voltage		2 500 V 1,2 / 50 μs
Overvoltage category		II
Insulation pollution degree		3
Dielectric strength		
• between coil and contacts		2 000 V AC type of insulation: basic
• contact clearance		1 000 V AC type of clearance: micro-disconnection
• pole - pole		2 000 V AC type of insulation: basic
Contact - coil distance		
• clearance		≥ 3 mm
• creepage		≥ 4 mm

### General data

Operating / release time (typical values)		AC: 8 ms / 7 ms	DC: 10 ms / 3 ms
Electrical life			
• resistive AC1		≥ 2 x 10 <sup>5</sup> 5 A, 250 V AC	
• cos φ		see Fig. 2	
Mechanical life (cycles)		≥ 10 <sup>7</sup>	
Dimensions (L x W x H)		27,5 x 14 x 32,9 mm	
Weight		22 g	
Ambient temperature			
• storage		-40...+70 °C	
• operating		-40...+55 °C	
Cover protection category		IP 40	PN-EN 60529
Shock resistance		10 g	
Vibration resistance		5 g 10...150 Hz	
Solder bath temperature		max. 270 °C	
Soldering time		max. 5 s	

The data in bold type pertain to the standard versions of the relays.

**Note:** relays with AgNi contacts can be used up to 5 A at resistive and inductive load.

**Coil data - DC voltage version**

Table 1

Coil code	Rated voltage V DC	Coil resistance ±10% at 20 °C Ω	Coil operating range V DC	
			min. (at 20°C)	max. (at 55°C)
1006	6	47	4,8	6,6
<b>1012</b>	<b>12</b>	<b>188</b>	<b>9,6</b>	<b>13,2</b>
<b>1024</b>	<b>24</b>	<b>750</b>	<b>19,2</b>	<b>26,4</b>
1048	48	2 660	38,4	52,8
1060	60	4 000	48,0	66,0
1080	80	7 100	64,0	88,0
1110	110	13 480	88,0	121,0

The data in bold type pertain to the standard versions of the relays.

**Coil data - AC 50/60 Hz voltage version**

Table 2

Coil code	Rated voltage V AC	Coil resistance ±10% at 20 °C Ω	Coil operating range V AC	
			min. (at 20°C)	max. (at 55°C)
5006	6	16	4,8	6,6
5012	12	68	9,6	13,2
<b>5024</b>	<b>24</b>	<b>270</b>	<b>19,2</b>	<b>26,4</b>
5050	50	1 150	40,0	55,0
5100	100	5 590	80,0	110,0
5110	110	5 670	88,0	121,0
5115	115	5 990	92,0	126,0
5120	120	6 390	96,0	132,0
5220	220	21 470	176,0	242,0
<b>5230</b>	<b>230</b>	<b>21 470</b>	<b>184,0</b>	<b>253,0</b>
5240	240	25 390	192,0	264,0

The data in bold type pertain to the standard versions of the relays.

**Dimensions - plug-in version**

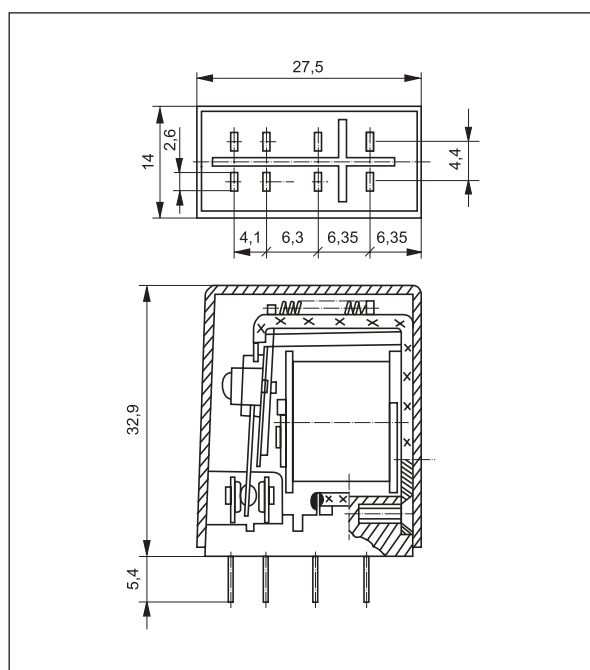

**Dimensions - PCB version**

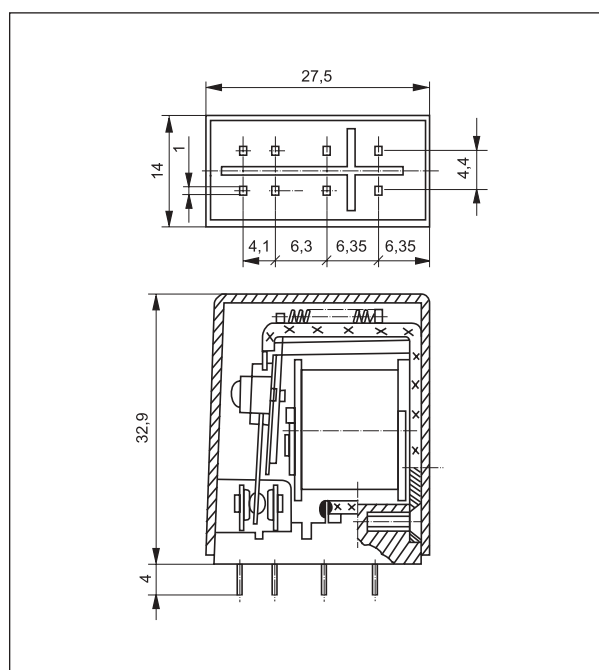

### Connection diagram (pin side view)

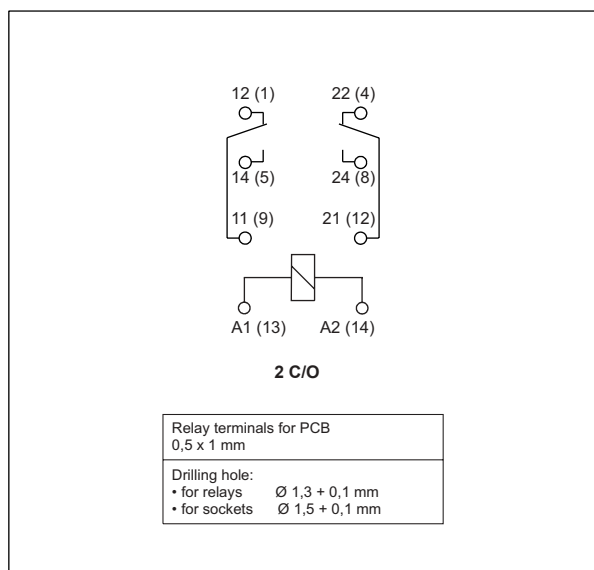

### Electrical life at AC reductive load

Fig. 1

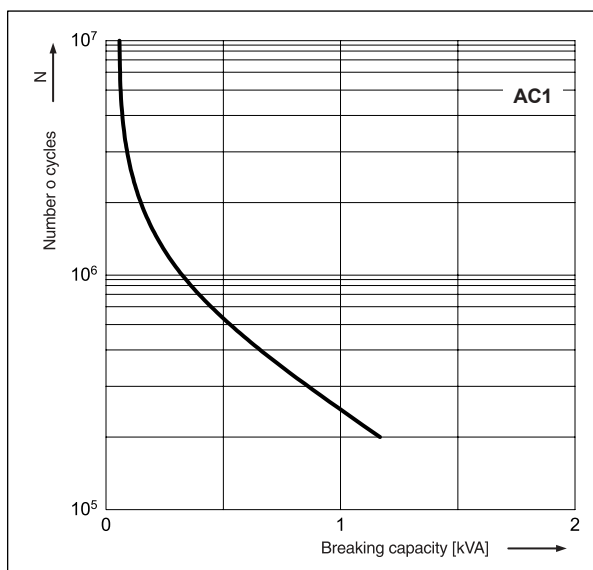

### Electrical life reduction factor at AC inductive load

Fig. 2

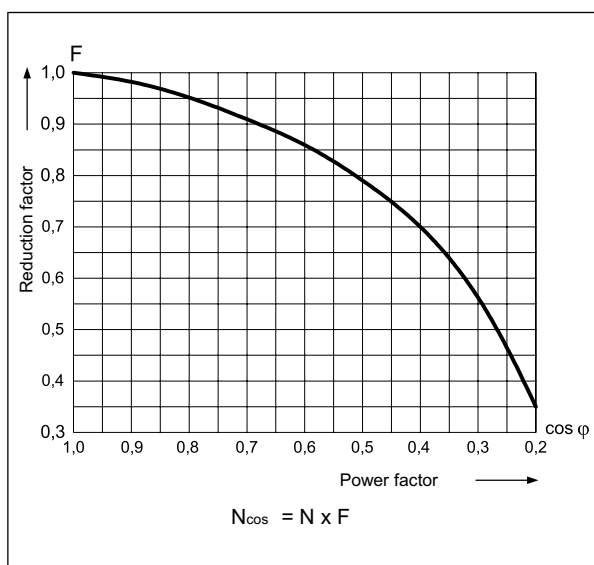

### Max. DC resistive load breaking capacity

Fig. 3

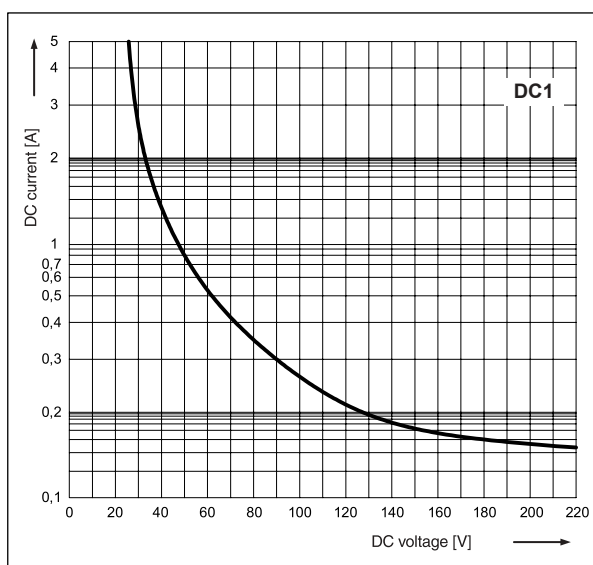

### Mounting

Relays **R2M** are designed for: • screw terminals plug-in sockets **G22** with clip **G22 1060** and spring clamp **G22 1111**, 35 mm rail mount acc. to PN-EN 60715 or on panel mounting with two M3 screws • plug-in sockets for PCB mounting **S2M** with clip **G4 1050** • solder terminals sockets **G2M** with clip **G4 1050** and spring clamp **G2M 1020** • direct PCB mounting.