

HF115F-Q

MINIATURE HIGH POWER RELAY



File No.: E134517



File No.: 116934



File No.: CQC08001025634



Features

- Ambient temperature up to 125 °C
- 5kV dielectric strength (between coil and contacts)
- Low height: 15.7mm
- Creepage distance >8mm
- Meeting VDE 0700, 0631 reinforce insulation
- UL94, V-0 flammability class
- Product in accordance to IEC 60335-1 available
- Class F insulation
- Environmental friendly product (RoHS compliant)
- Outline Dimensions: Vertical: (41.0 x 12.7 x 15.7) mm
Horizontal: (45.0 x 12.7 x 15.7) mm

CONTACT DATA

Contact arrangement	1A, 1B
Contact resistance	100mΩ (at 1A 6VDC)
Contact material	AgSnO ₂ , AgNi
Contact rating	20A 250VAC
Max. switching voltage	440VAC / 125VDC
Max. switching current	20A
Max. switching power	5000VA
Mechanical endurance	1 x 10 ⁷ OPS
Electrical endurance	1 x 10 ⁵ OPS (See approval reports for more details)

CHARACTERISTICS

Insulation resistance	1000MΩ (at 500VDC)	
Dielectric strength	Between coil & contacts	5000VAC 1min
	Between open contacts	1000VAC 1min
Surge voltage (between coil & contacts)	10kV (1.2 x 50μs)	
Operate time (at nomi. volt.)	15ms max.	
Release time (at nomi. volt.)	8ms max.	
Temperature rise (at nomi. volt.)	55K max.	
Shock resistance *	Functional	98m/s ²
	Destructive	980m/s ²
Vibration resistance *	1A: 10Hz to150Hz 10g 1B: 10Hz to150Hz 5g	
Humidity	35% to 85% RH	
Ambient temperature	-40°C to 125°C	
Termination	PCB & QC	
Unit weight	Approx. 16g	
Construction	Flux proofed	

Notes: 1) The data shown above are initial values.
2) * Index is not that of relay length direction.

COIL

Coil power	400mW
------------	-------

COIL DATA

at 23°C

Nominal Voltage VDC	Pick-up Voltage VDC	Drop-out Voltage VDC	Max. Allowable Voltage VDC	Coil Resistance Ω
5	3.50	0.5	7.5	62 x (1±10%)
6	4.20	0.6	9.0	90 x (1±10%)
9	6.30	0.9	13.5	202 x (1±10%)
12	8.40	1.2	18.0	360 x (1±10%)
18	12.6	1.8	27.0	810 x (1±10%)
24	16.8	2.4	36.0	1440 x (1±10%)
48	33.6	4.8	72.0	5760 x (1±15%)
60	42.0	6.0	90.0	7500 x (1±15%)
110	77.0	11.0	165.0	25200 x (1±15%)

Notes: The max. allowable voltage in the COIL DATA is coil overdrive voltage, it is the instantaneous max. voltage which the relay coil could endure in a very short time.

SAFETY APPROVAL RATINGS

VDE	AgNi	1 Form A	18A 250VAC 105°C 16A 250VAC 125°C 12A 400VAC 105°C
		1 Form B	16A 250VAC 125°C 12A 400VAC 105°C
UL&CUL	AgNi	1 Form A 1 Form B	20A 277VAC

Notes: Only some typical ratings are listed above. If more details are required, please contact us.



HONGFA RELAY

ISO9001, ISO/TS16949, ISO14001, OHSAS18001, IECQ QC 080000 CERTIFIED

2009 Rev. 1.11

ORDERING INFORMATION

Type	HF115F-Q / 012 -1H 3 T (XXX)				
Coil voltage	5, 6, 9, 12, 18, 24, 48, 60, 110VDC				
Contact arrangement	1H: 1 Form A	1D: 1 Form B			
Terminals	3: Quick connect terminals horizontal		Nil: Quick connect terminals vertical		
Contact material	T: AgSnO ₂	Nil: AgNi			
Customer special code	e.g. (335) stands for product in accordance to IEC 60335-1 (GWT)				

OUTLINE DIMENSIONS, WIRING DIAGRAM AND PC BOARD LAYOUT

Unit: mm

Outline Dimensions

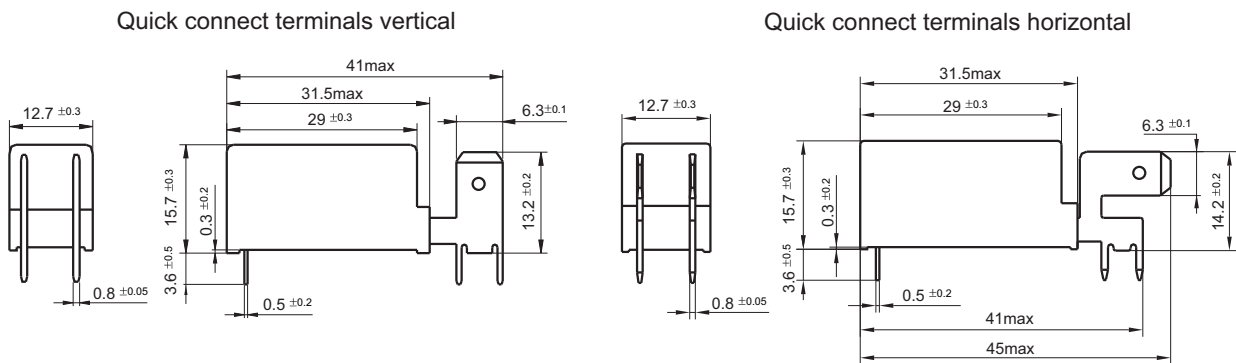

Wiring Diagram (Bottom view)

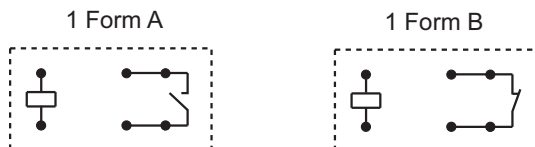

PCB Layout (Bottom view)

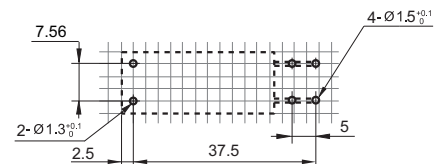

- Remark: 1) In case of no tolerance shown in outline dimension: outline dimension ≤ 1 mm, tolerance should be ± 0.2 mm; outline dimension > 1 mm and ≤ 5 mm, tolerance should be ± 0.3 mm; outline dimension > 5 mm, tolerance should be ± 0.4 mm.
 2) The tolerance without indicating for PCB layout is always ± 0.1 mm.
 3) The width of the gridding is 2.52mm.

CHARACTERISTIC CURVES

MAXIMUM SWITCHING POWER

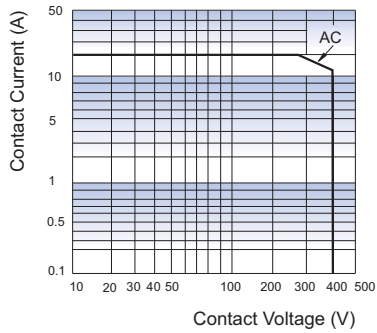

ENDURANCE CURVE

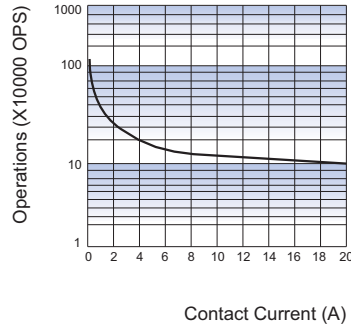

COIL OPERATING RANGE (DC)

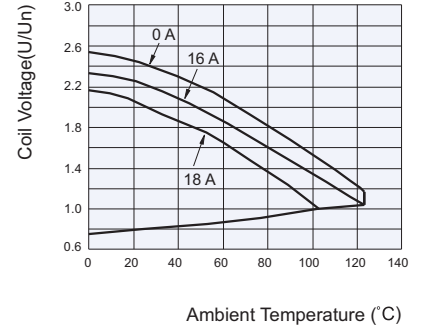

Disclaimer

This datasheet is for the customers' reference. All the specifications are subject to change without notice.

We could not evaluate all the performance and all the parameters for every possible application. Thus the user should be in a right position to choose the suitable product for their own application. If there is any query, please contact Hongfa for the technical service. However, it is the user's responsibility to determine which product should be used only.